



INTERCALL®

INTERCALL'S VIDEO MANAGED SERVICES

InterCall's® InView® solution provides industry-recognized multipoint video conference services, applications and training to conference leaders around the world. Business professionals have come to depend on our flawless conference executions time after time. With Video Managed Services, InterCall becomes your one point of contact for all your video conferencing needs.

InterCall's Video Managed Services (IVMS) represent a collection of capabilities which allow you to outsource the management of some or all of your video conferencing services to the experienced InView video services team at InterCall. Under the IVMS umbrella, InterCall offers everything from remote and on-premise bridge management solutions to web-based scheduling and conference resource management to onsite support personnel to handle call monitoring and equipment maintenance.

For information about IVMS, please contact InterCall's Video Services Team at WWW.INVIEW.NET/CONTACT.HTM

Because each customer's requirements for an IVMS solution are unique, below are some examples of how this flexible model has been applied with actual InterCall customers. (InterCall does not provide customer names per corporate policy).

▶ CASE STUDY: MANAGED BRIDGE ON INTERCALL PREMISES

Customer Requirements:

"Customer A" is a demanding user of video conferencing, with a dedicated internal resource group that specifically oversees the onsite support of video sites and technology. User training, adoption, and video conference utilization all flow down through this group from a service management perspective. They understand the need for technical support, and wish to leverage the expertise of an outside vendor experienced in video conferencing applications in order to optimize their performance. In addition, they wish to utilize a web-based scheduling application so that the internal service management team has can continue to manage the service delivery.

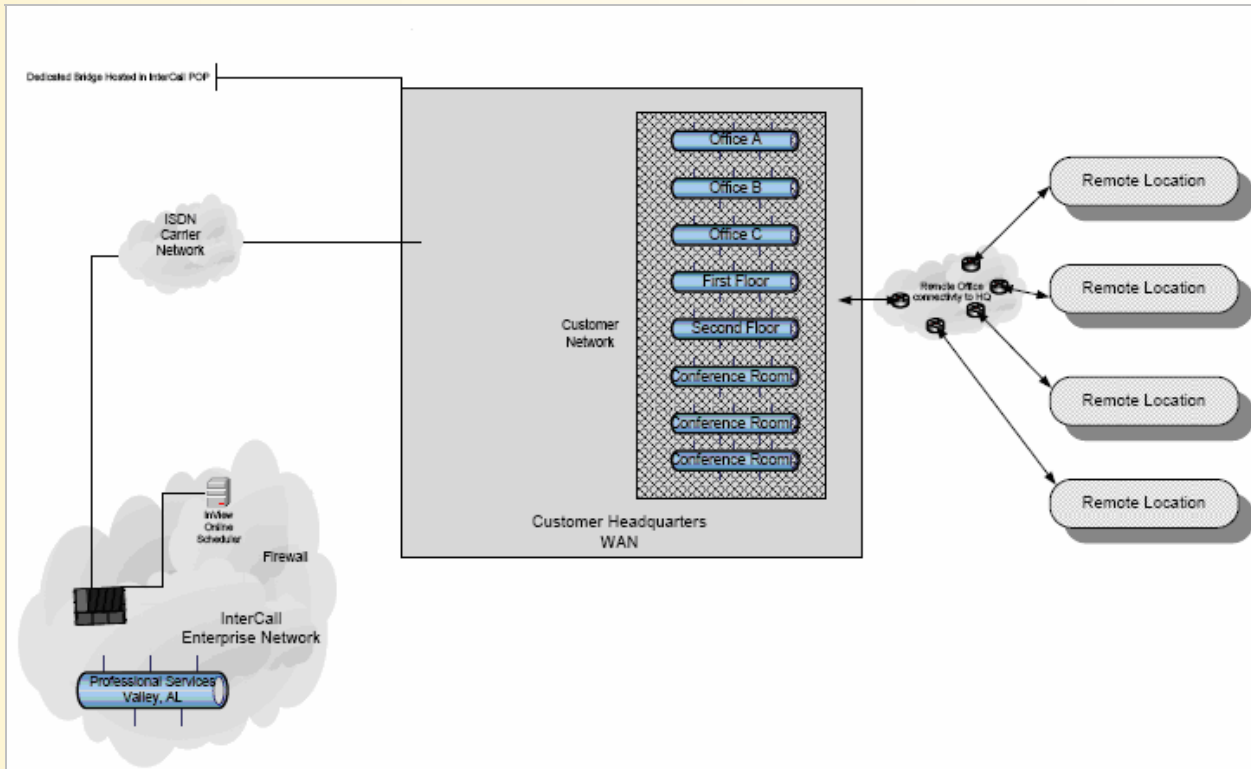

Diagram 1-a, Customer network environment



There are over 300 video devices/locations that this customer can utilize at any time (some of these sites are customer or contractor sites), and the majority of communications happen over ISDN or switched digital circuits. The bridge configuration (see diagram 1-a, above) dedicates ISDN routing and bridge numbers, while external communications are routed to the service provider switch in order to dial out through multiple carriers for circuit redundancy. IP traffic can also be handled through the bridge configuration design.

InterCall's Answer:

In order to successfully route the calls, and provide proactive troubleshooting processes, InterCall designed a branded 800 number for the customer, and dedicated resources to answer all technical support calls. InterCall also provided the means for additional agents to back up the primary team through their call center ACD. As calls enter the system, the following flows are put into place (see diagram 1-b).

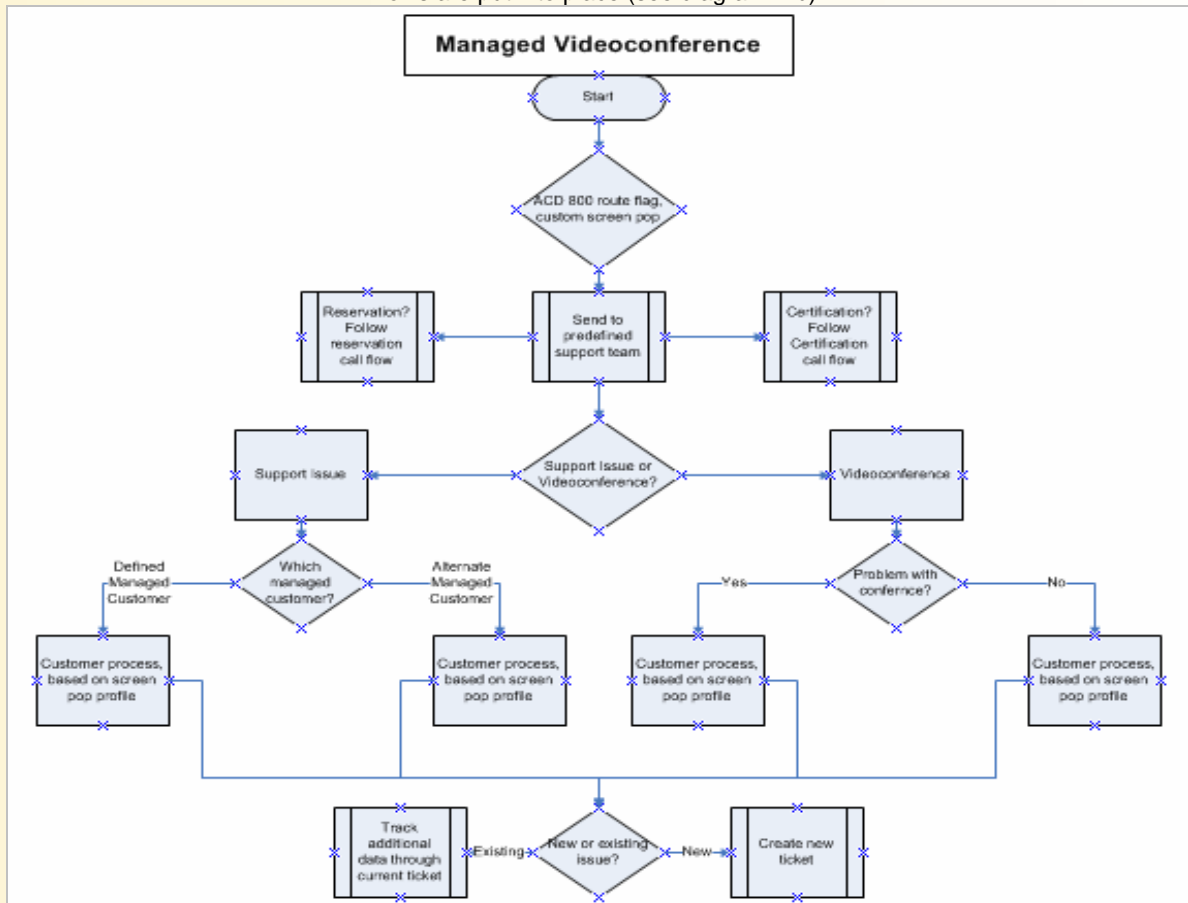

Diagram 1-b InterCall process/solution flow for Managed services Customer A

InterCall has also provided InView Online, our web based scheduler, to this customer. While InterCall controls the high level functionality of the interface, a customized user platform was provided specifically for this customer. This user login and access allows the on-site service management team to add and delete system users, and edit room information and device information. All conferences are entered into the system. At the appropriate time, the web-based scheduler communicates to the bridge device control, loads all reservation details to the call profile, and initiates the call for the customer by dialing out to all endpoints. This ease of call start provides the users with a pleasant, user-friendly experience, as they no longer need to control the device to initiate the call. Calls are started on-time as compared to dial-in conferences, as all sites are connected and confirmed as receiving audio and video before the conference start time. (Dial-in can be requested if needed).

All video conferences and technical calls (whether issue related or not) are logged by InterCall technical support personnel, allowing for statistics to be run on call flows, trouble tickets, and conference tickets. We are able to provide this customer (via weekly conference calls) with the status of any issues, resolution, and closure.



▶ CASE STUDY: MANAGED BRIDGE ON CUSTOMER PREMISE

Customer Requirements:

“Customer B” has an environment where gatekeeper services, E.164 dialing, desktop based video, room based video, and bridge management are all handled by an internal resource. InterCall was requested to take over the management of all of the above as the Gatekeeper management, user registration, multipoint management and reservations, and remote bridge management, as the internal resources were being removed.

InterCall’s Answer

In order to mirror and improve the experience of the current environment, InterCall worked with the customer’s internal video conferencing resources to develop a plan whereby all services listed above would move to InterCall call center resources. This included reworking some ISDN access and switch routing configurations in order to provide consistent services (see diagram 2-a). In addition, InterCall added InView Online to this customer’s video conferencing experience in order to ease the reservation process for internal users of video conferencing. This requires a stateful connection from InterCall premise to customer premise bridge. Once stateful connection is confirmed as active, InView Online application downloads all conference details to customer premise bridge in the same way as any InterCall premise bridge (including CDR).

A management path was opened from InterCall’s extranet to the customer premise. This allows InterCall to manage all onsite infrastructure equipment. InterCall also owns the video bridge and Gatekeeper on the customer premise, and is responsible for all break-fix and issue resolution; once again through the InView Online ticket management system.

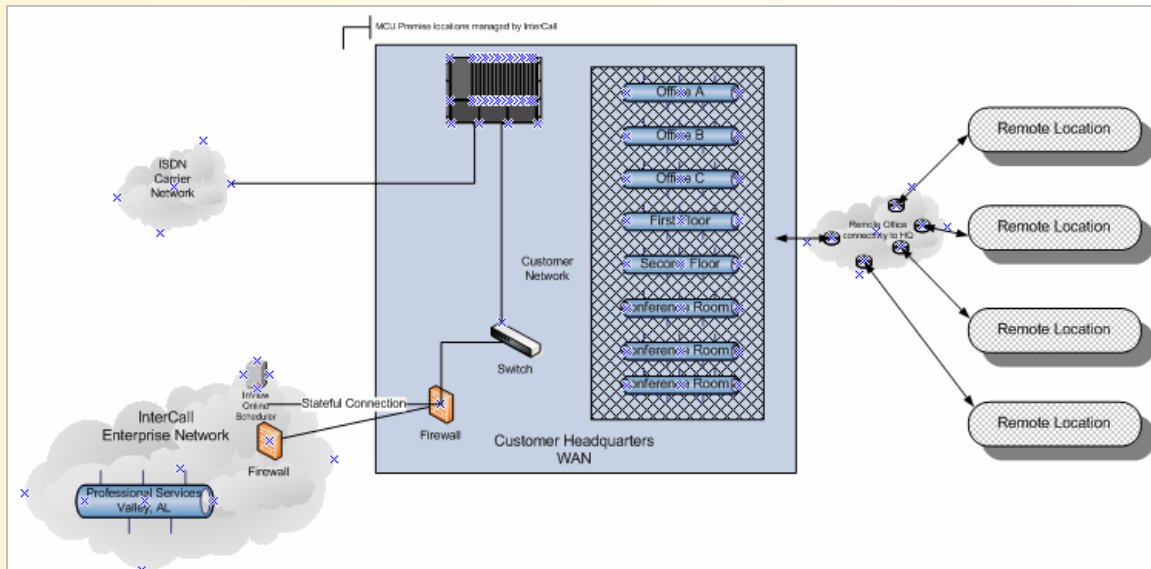

Diagram 2-a, Customer B network environment



▶ CASE STUDY: REMOTE ENDPOINT MANAGEMENT AND CALL LAUNCH

Customer Requirements:

“Customer C” provides video rental services through various US based locations, and had a need for a partner to front all incoming reservations, call launch from the endpoint to external customer or bridge, and provide SLA reporting on customer response and service quality levels. Additionally, for any conferences that also needed bridge resources, InterCall was required to provide these services through its own video service provider bridge infrastructure.

InterCall’s Answer:

InterCall designed a customized application to communicate with CPU-based video conferencing systems located in various facilities throughout the United States. This application, in conjunction with the reservations managed by InterCall, enables us to maintain call quality and service levels through this Video Managed Network Services monitoring layout (see diagram 3-a). It also allows InterCall technicians to extend any in-progress conference on behalf of the customer automatically.

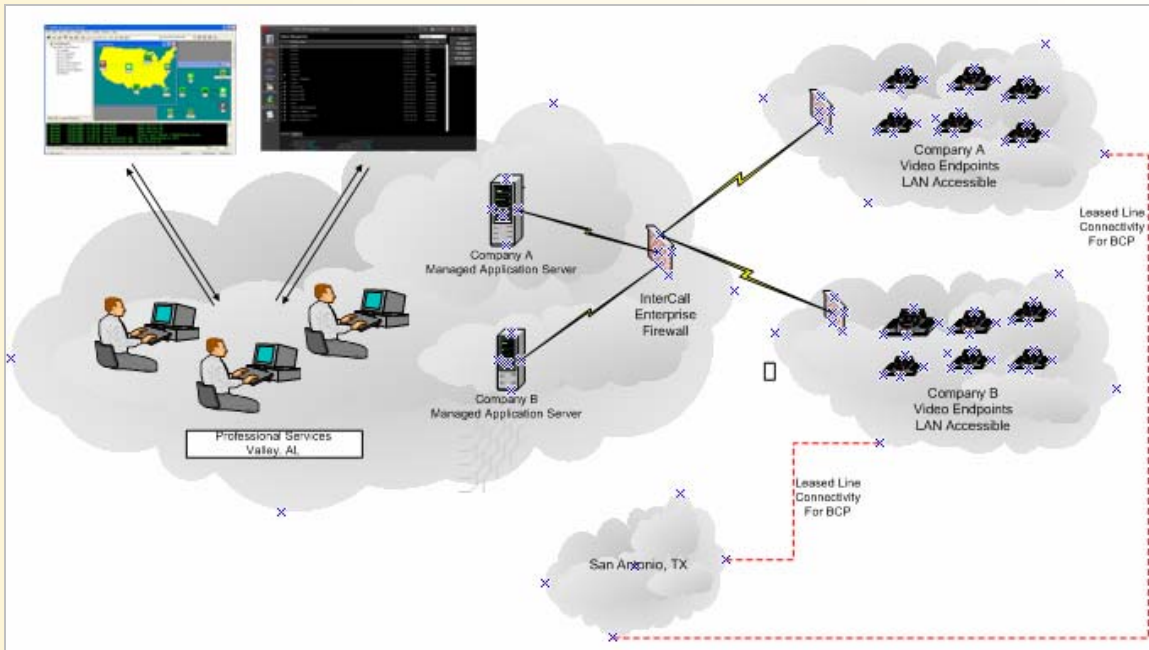

Diagram 3-a, Customer C network environment

All conferences are launched from the endpoint GUI at the video rental location, and either dialed into an InterCall bridge (for multipoint or gateway conferences), or direct-dial for ISDN point-to-point services. Trouble shooting of all endpoints is also handled by InterCall on a duplicate system on InterCall premise (this setup mimics the video rental room setup in every fashion, including the power, system, network closet, and switch). If equipment issues need to be escalated, they are handed off with the escalation report to the equipment maintenance provider, and on-site support can be provided in the most timely manner. When an outage does occur and service is required, the system is placed out of service with estimated work timeframes, and all active reservations within the ticket work window are moved to other rental locations during the outage. This “Out of Service” window was developed for this customer and is utilized through InView Online.

Again, as in the previous examples, a specific team of agents is responsible for attending to this customer, and escalation can take place outside of the group through backup resources as appropriate. Call flows cover both incoming customer reservations as well as technical escalation. In the original build-out of services, the customer also requested for a 10 day window view into upcoming reservations, and from this a fax list was sent to each store for their daily conferences. Since the original build out, InView Online now provides the ability to view location by location reservations for any day, past or future, with no limit on the reservation data displayed.



▶ CASE STUDY: MPLS NETWORK INTEGRATION

Customer Requirements:

“Customer D” had installed and used video conferencing in the past for internal and customer-facing communications. They controlled the experience for approximately 20 ISDN-based endpoints, 3 of which were AV integrated room-based systems. Reliability and connectivity were issues that led to limited adoption and decreased use of video conferencing, and the customer was not realizing the greatest return for their investment. Customer D wanted to deploy an MPLS network based video conferencing system to improve functionality and give a consistent service experience for users.

InterCall’s Answer:

InterCall, in partnership with Sprint, was awarded the opportunity to deploy the MPLS video conferencing network for this customer, and SPL Integrated Solutions provided the room integration. Though both Data and VoIP were carried on this provisioned network, IP-based video conferencing could also be handled. Carrying the video traffic over this network scenario managed by Sprint would allow for the reliability and quality this customer was seeking.

Customer D was also able to leverage this infrastructure to increase the sites available for video conferencing, and wanted to provision a 25 port bridge in conjunction with the services. This bridge was located in an InterCall data center, and the MPLS network from Sprint was provisioned to include this location as one of the network spokes (see diagram 4-a). An ISDN gateway was also provided via the bridge, and this implementation cut down the number of customer-provisioned ISDN lines. All Point-to-Point and Multipoint conferences are handled by the bridge, and, are scheduled and managed through InView Online, InterCall’s web based scheduling system.

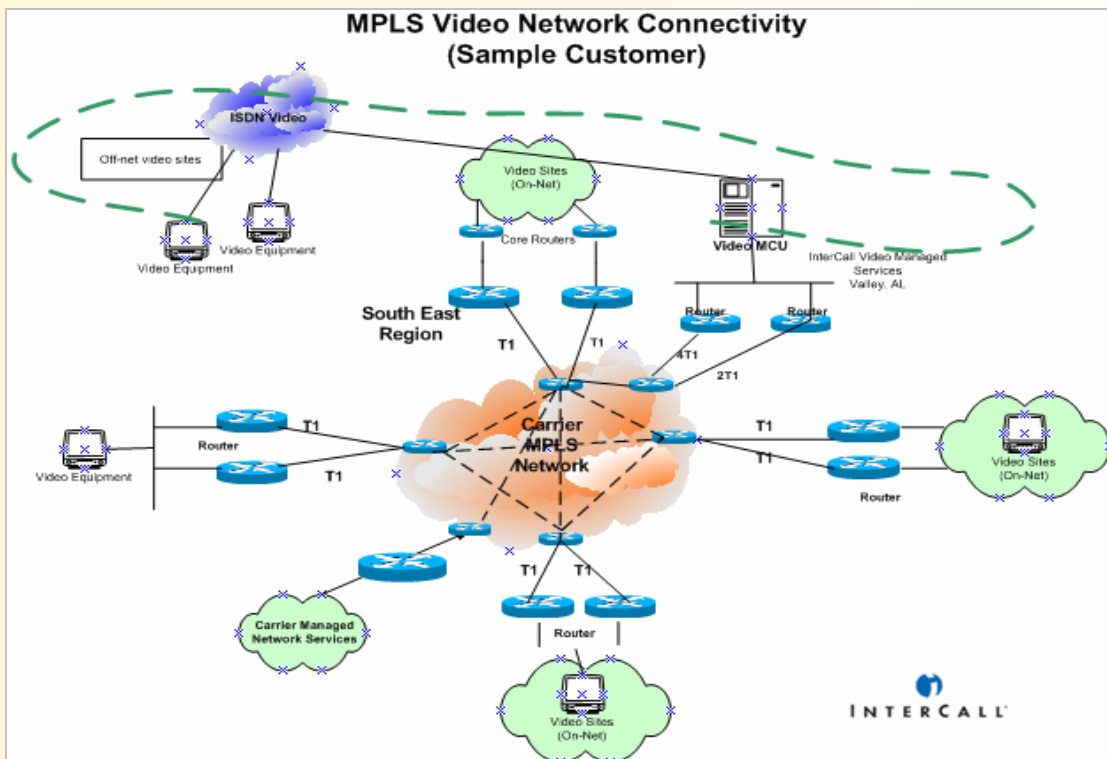

Diagram 4-a, Customer D network environment



INTERCALL®

The customer was provided with documentation and training on their new room-based systems, and the video conference management team was trained to use InView Online. Training was also provided to the room users on the A/V capabilities of each room for use outside of video conference calls.

Helpdesk and Maintenance support and call center contact information is also provided to this customer through the InterCall and SPL relationship, and this system ensures that all systems are working properly by utilizing commercially available endpoint monitoring tools, programmed alarming, reporting, and certification services for outside or legacy sites. A customized call flow was again utilized, understanding that for this customer we would be working with an internal management group, instead of directly with the end-user customers.

CONCLUSION

As you work through the process of determining your specific needs, please use this overview as a reference guide and inspiration to help you formulate the solution you need. All IVMS customers receive a specifically designed plan for their own network and requirements, so work with our team to develop your own solution.

**For information about IVMS, please contact InterCall's Video Services Team at
WWW.INVIEW.NET/CONTACT.HTM**

